

Multilink Blvd

Multilink[®]
Simply More...



Street Brite

LED ILLUMINATED STREET SIGN



Field Serviceable
5 Year Warranty
500% Longer Bulb Life
65% Lighter Weight
Go Green
50% Thinner Than Traditional LED Signs



Distributed by **TAPCO**
Safe travels.

1-800-236-0112
www.tapconet.com

GSA
Contract Holder
GS-507-25924R
GS-507-40224U

GoMultilink.com
OMNIA
PARTNERS

Street Brite

LED ILLUMINATED STREET SIGN



Mounting Options

PELCO SE-5146

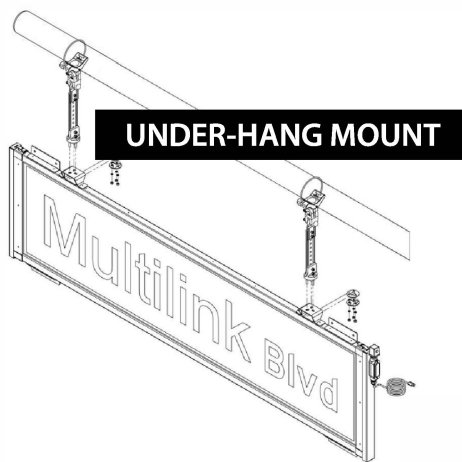

PELCO AS-0661

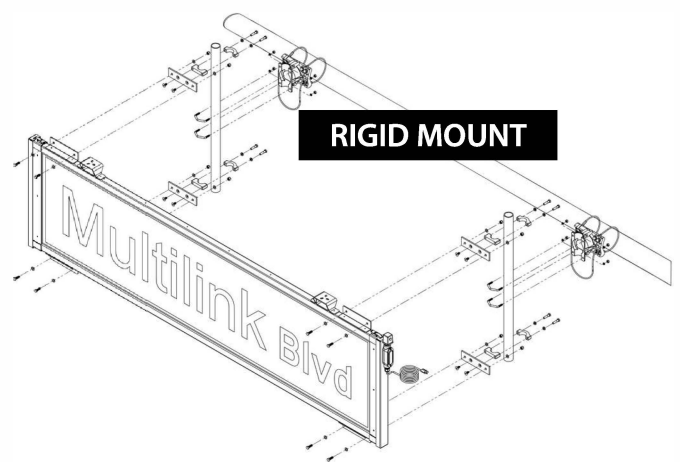

2"
**ACTUAL
SIZE**



Reliability,
Accessibility,
and Visibility

Unmatched in the industry, the Street Brite Sign's heavy-duty frame is constructed with aircraft-grade, 8-gauge aluminum.

It can withstand **wind speeds up to 150 miles per hour** and is **2/3 the weight of other back-lit signage**.

The sign's 3M translucent material illuminates as well as reflects to maintain zero shadow stabilization in all lighting conditions.

***Designed to meet FDOT
* Specifications***